

SULZER

Nordic Water

Filtration solutions

DynaDrum

self-cleaning drum filter

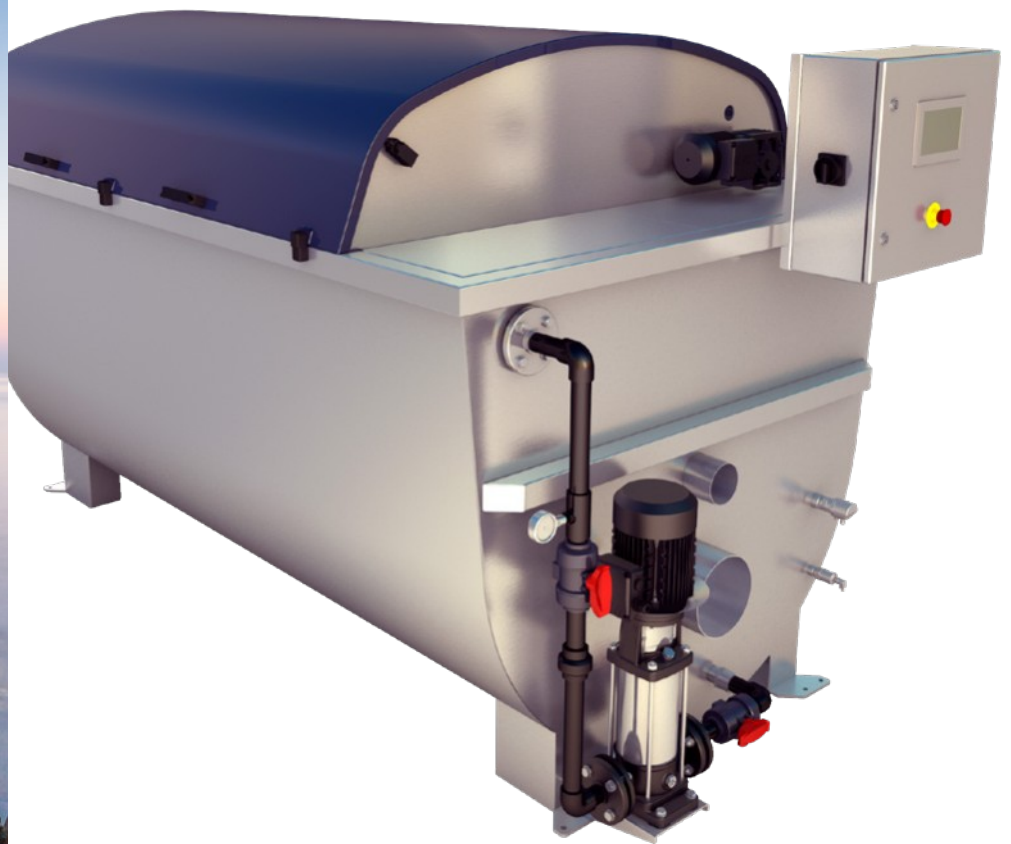

Main industries and applications

The DynaDrum is an automatically self-cleaning micro-screen filter designed for reliable and efficient removal of suspended solids down to the size of 10 microns. It is part of our application Nordic[®] Primary, a modern wastewater treatment plant design.

The DynaDrum drum filter is available in a variety of sizes and designs for use in applications such as:

- Food industry effluents
- Effluent polishing of wastewater
- Fish farming systems
- Transport water in plastic industry
- Intake water filtration
- Pre-filtration before sand filters
- Pulp and paper industry
- Reuse water
- Industrial process water filtration

How DynaDrum works

The DynaDrum comprises of several filter panels mounted around a rotating inlet drum and provides a simple yet robust solution for the removal of fine particles.

The water to be filtered enters the drum via the inlet and gravitates out through the filter in the drum outer edges. The particles are separated and stick to the inside of the filter.

When the water level in the drum reaches a preset level, the drum starts to rotate, and the filter backflush starts. By means of high-pressure washing DynaDrum uses the filtered water to safely remove the suspended solids through the reject.

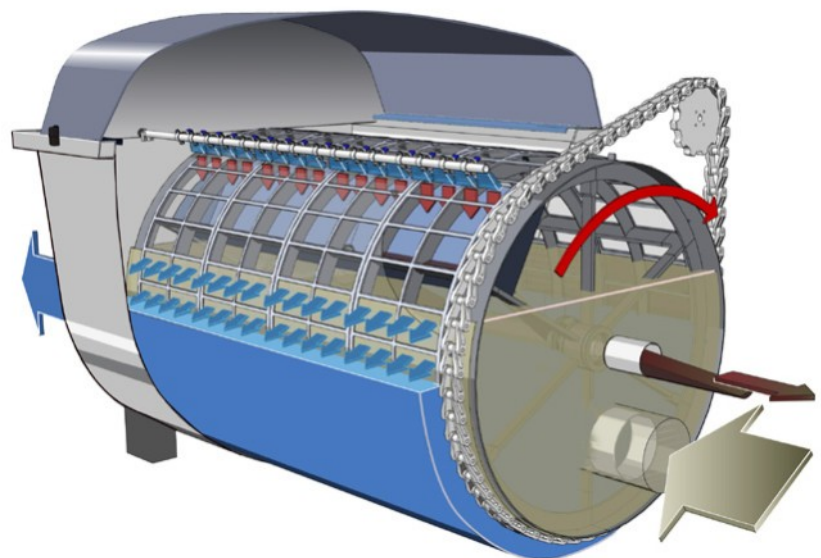

Features and benefits

The DynaDrum benefits from low energy consumption since it operates without pressure and has a very low head loss. The combination of low energy consumption and a reliable design results in a remarkably low life-cycle cost.

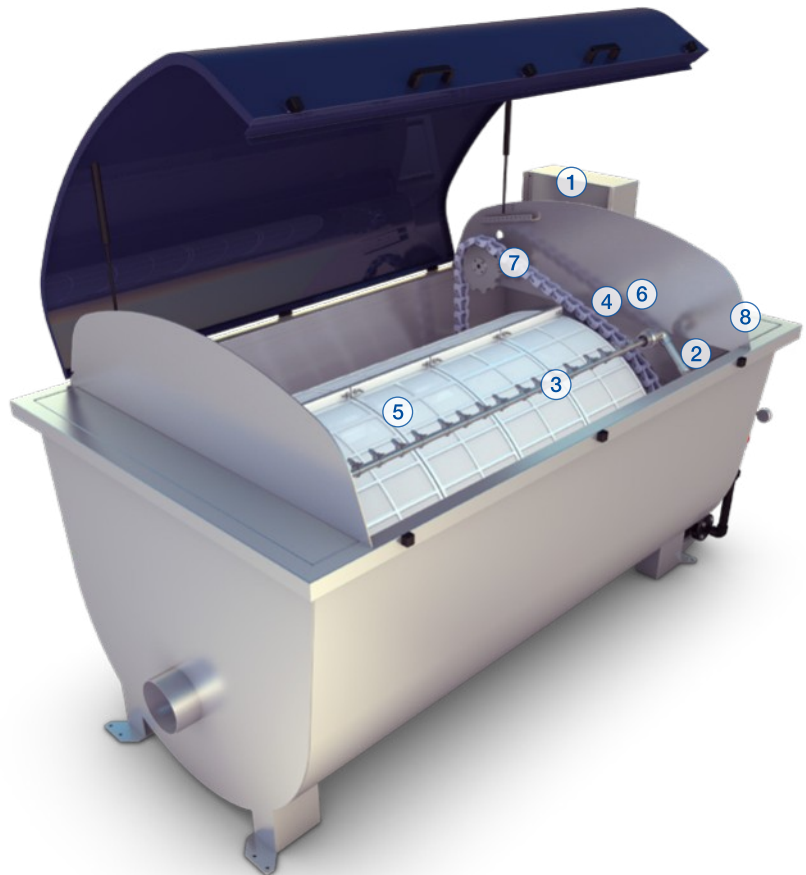

1 Control system for easy and efficient management

- Automatic control system with user friendly interface through a touch panel

2 Backwash control for low water and energy consumption

- Backwash control via analog level transmitter and frequency converters for backwash pump and rotor drive. Maximum backwash efficiency and minimized energy consumption
- Model TDD/CDD1212 and larger has oscillating backwash system which reduces the number of backwash nozzles installed and the volume of backwash water used

3 Spray nozzle – new design minimizes clogging

- New type of spray nozzle with high efficiency and minimized risk for clogging

4 Drum and inlet sealing for easy maintenance

- Innovative design of drum and inlet sealing for quick service

5 Filter panel for easy installation

- Filter panel with integrated fastening device for quick and easy installation/replacement

6 Reject water trough saves water

- Adjustable reject water trough to allow for circulation of separated solids and lowest amount of water in reject

7 Chain drive for continuous operation

- Lubrication free and corrosion free chain drive

8 Emergency overflow weirs ensures safe operation

- Built-in emergency overflow weirs at inlet side for internal or optionally external bypass

Models and materials

Selection of materials to fit any requirements

DynaDrum is available in different models and sizes, to suit the needs for different installations, regarding footprint and capacity as well as the choice of material.

Construction materials are chosen depending on water quality. Material of frame and drum can be stainless steel, acid proof steel or duplex steel. Covers are made of FRP as standard but are also available in stainless steel. The filter cloth is made of polyester or stainless steel.

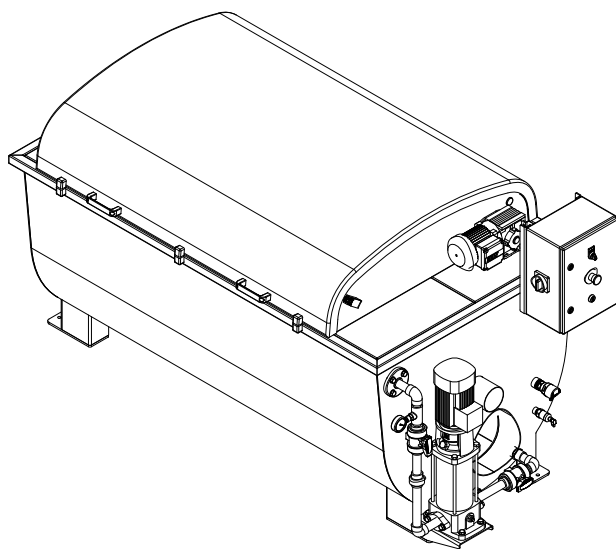

TDD – Tank design:
tank of stainless steel, cover of FRP

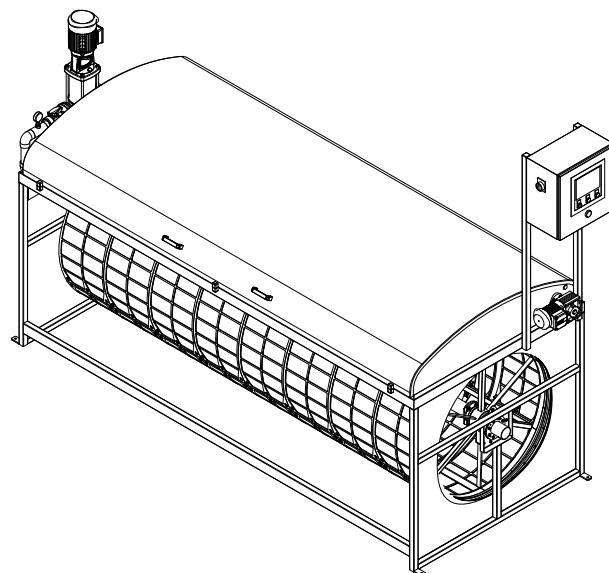

CDD – Concrete design:
frame of stainless steel, cover of FRP

Sustainable filtration without chemicals

Nordic Primary – extensive primary filtration design

The modern wastewater treatment plant application design Nordic Primary has radically illuminated the benefits of primary filtration in modern pre-treatment processes to:

- Provide high level of treatment
- Reduce energy requirements
- Decrease plant footprint
- Lower overall carbon footprint
- Higher valuable sludge than conventional primary sedimentation designs

Removing solids during the early stages of the treatment process improves the efficiency of the downstream biological stages. The primary filtration sludge normally contains much more energy to be used in the digestion chamber.

The technology can be used for capacity expansion of existing wastewater treatment plants where space and land are often restricted within urban cities.

The complete treatment plant is often built above ground without concrete basins. The first stage of MevaScreen and MevaPress are proven to efficiently reduce microplastics and screenings for combustion. Sand and grit are separated before the water passes the DynaBelt filter and DynaDrum microscreens.

The primary sludge is pressed to the degree suitable for the digester. Typical Nordic Primary design is a separation without use of chemicals, but more ambitious SS removal or phosphate removal could be performed with the same equipment but with the support by polyelectrolytes and coagulants.

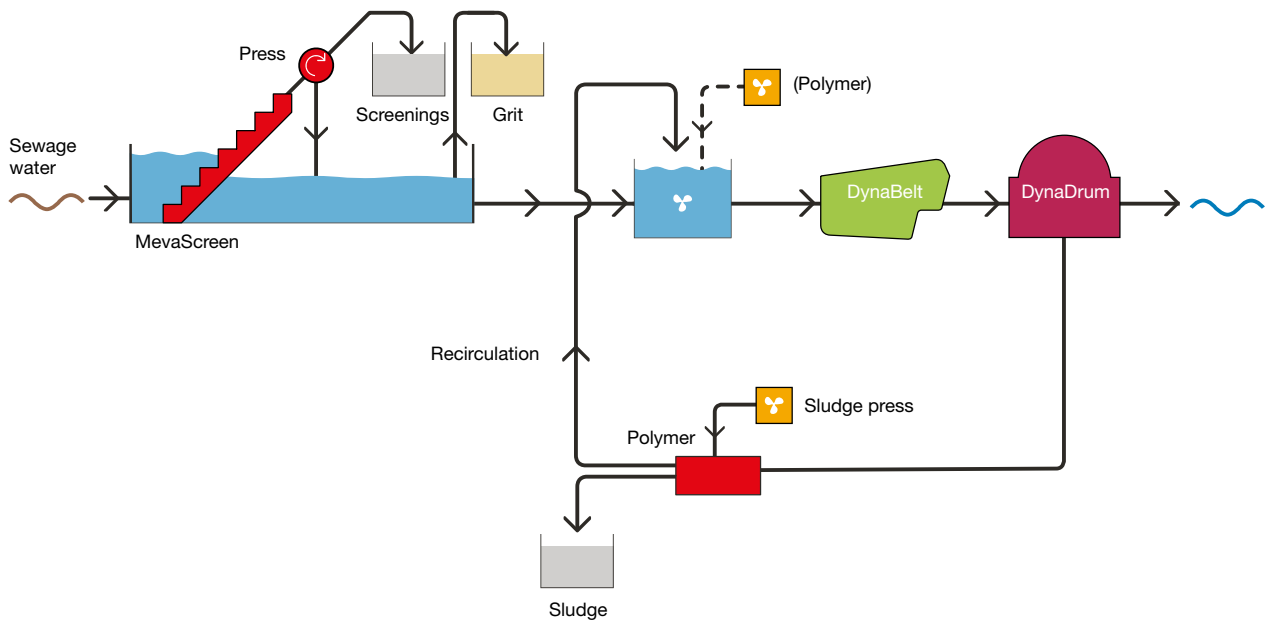

The Sulzer Flow division keeps your processes flowing. Wherever fluids are treated, pumped, or mixed, we deliver highly innovative and reliable solutions for the most demanding applications.

The Flow division specializes in pumping solutions specifically engineered for the processes of our customers. We provide pumps, agitators, compressors, grinders, screens and filters developed through intensive research and development in fluid dynamics and advanced materials. We are a market leader in pumping solutions for water, oil and gas, power, chemicals and most industrial segments.

E10787 en 9.2024, Copyright © Sulzer Ltd 2024

This brochure is a general presentation. It does not provide any warranty or guarantee of any kind. Please, contact us for a description of the warranties and guarantees offered with our products. Directions for use and safety will be given separately. All information herein is subject to change without notice.

