

SULZER

Nordic Water

Sedimentation solutions

Zickert sludge scrapers and equipment for sedimentation



Main industries and applications

The Zickert sludge scrapers are designed for continuous sludge transport and performs well in all sedimentation processes. The Zickert scrapers are designed for use in rectangular or circular shaped sedimentation tanks in applications such as:

- Wastewater treatment plants
- Drinking-water purification plants
- Industrial processes
- Floatation plants
- In combination with Lamella systems

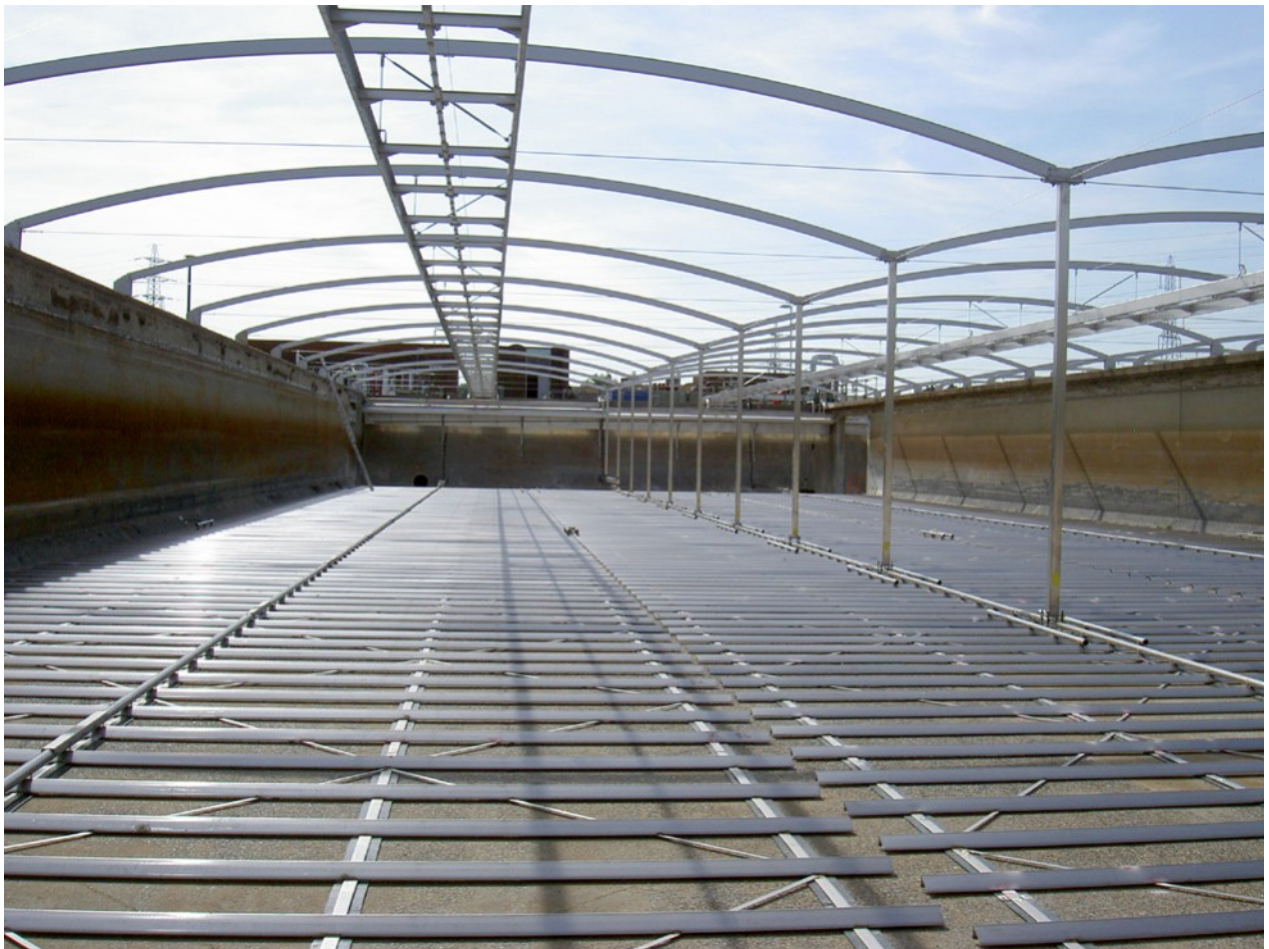

The adaptable sludge scrapers

Zickert sludge scrapers for rectangular tanks can be adapted to the most varied requirements as they do not depend on where the drive unit is located. They can be easily fitted around obstacles such as support pillars inside the tank. Zickert sludge scrapers are available with hydraulic drive or electric gear motor.

The hydrodynamically shaped scraper profile increase solids removal and the repeated movements of the profiles have the effect of thickening the sludge.

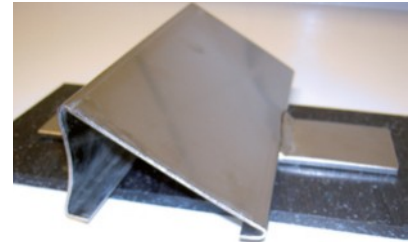

Bottom sludge scraper

The Zickert bottom sludge scraper provides continuous sludge transportation and acts as a moving floor in the tank. It removes the sediment blanket from the underside and transport the sediment towards the sludge pit. The unique design of the profiles leads to a highly efficient sludge collection without causing any turbulence or disturbance to the sedimentation process or sludge layer. The complete structure moves only in the absolute bottom of the sludge layer, which results in the densest and most concentrated part of the sludge being removed while the more dilute sludge above is not accompanied.

Surface sludge scraper

The Zickert surface sludge scraper is used to effectively remove surface sludge without removing unnecessary transport water in rectangular tanks. It is suitable for most applications where surface sludge occurs, both in municipal treatment plants and in industrial processes.

The scraper blade draws off sludge from the entire surface of the tank and takes it to a scum pipe or scum beach. The blade is fixed to a sledge which is propelled step by step by the drive bar. The sledge changes its direction of movement at each end of its journey. This means that several interacting sledges with scraper blades can be used in the same tank. For the return movement, the scraper blade swings up to avoid the sludge.



The innovative circular bridgeless scrapers

Zickert circular bridgeless sludge scraper is developed with a new innovative and patented driving design. The scraper is used to remove bottom sludge and, optionally, floating foam in circular sedimentation tanks. A travelling bridge structure is not required as the drive unit is installed fixed to the tank side. The scraper is electrically powered by a gear motor which can either be a dry installation at top of the tank or submerged drive inside the tank.

The specially designed drive wheel powers a drive ring along the tank wall and rotates the scraper arm around the tank. Scraper blades, that transport the sludge towards the center of the tank, are attached below the scraper arm.



The scraper can be equipped with a peripheral surface scraper, supported from the bottom scraper arm. The surface scraper collects the surface foam in the scum box unit which is attached to the concrete wall. The sludge is removed from the scum box through pipes in the concrete wall.

Application accessories

Siphon Z6600 sludge system

Siphon Z6600 is a system for continuous sludge removal in rectangular sedimentation tanks. The principle of the system is that several pipes are positioned vertically across the width of a tank. With the help of the siphon effect, the sludge is sucked up through the pipes to a common sludge duct. An extra air supply can be added for applications where capacity needs to be varied during operation. The system is cost-effective and requires very little maintenance and service.

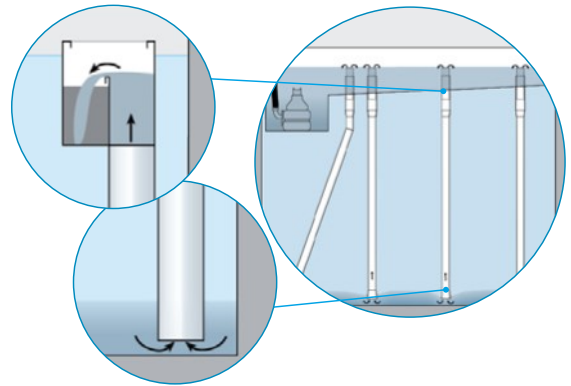

Scum pipes and scum beach

Scum collection pipes are used to collect surface scum and remove it from the tank. The rotating scum pipe is best suited for use with sludges with a low total solids content.

For sludge types that have a high total solids content, the scum beach is used. The scum beach is a fixed installation and can be fitted either on an existing concrete trough in the tank or combined with a scum pipe made of sheet steel as a permanent installation.



Sludge plate

For applications that require less sludge flow, the Zickert sludge plate can be an alternative in tanks that has a small flushing channel or no hopper at all. The sludge plate is installed to create a confined compartment between the plate and the sludge collection tank. The sludge is removed by a sludge valve through the tank wall and the solution will enable a highly efficient sludge removal.

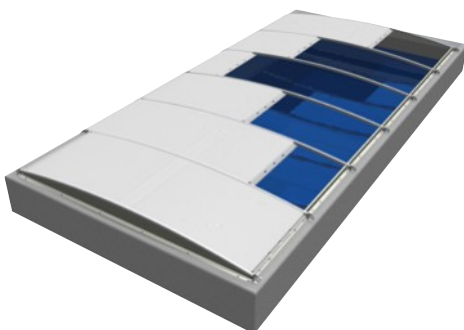

Reliable and cost-efficient covers

Covering the tanks at wastewater plants located nearby residential or working areas and cleaning the air, is an efficient solution to prevent odor and other volatile substances from leaving the tank. The cover reduces corrosion and heat loss at the same time as the security of the personnel is increased and in drinking water applications it provides a hygienic barrier.

The covering made of an UV-resistant membrane has a very low profile, which minimizes the air volume that needs to be cleaned. The cover is divided into sections and is easy to open and close by hand.

Features and benefits

Zickert sludge scrapers

With its very low profile, the Zickert scraper is ideal for installations underneath lamellas. It causes a minimal turbulence to the sludge layer and has no interference with sedimentation. The distance between the tank bottom and lamellas can be kept to a minimum while ensuring the process quality.

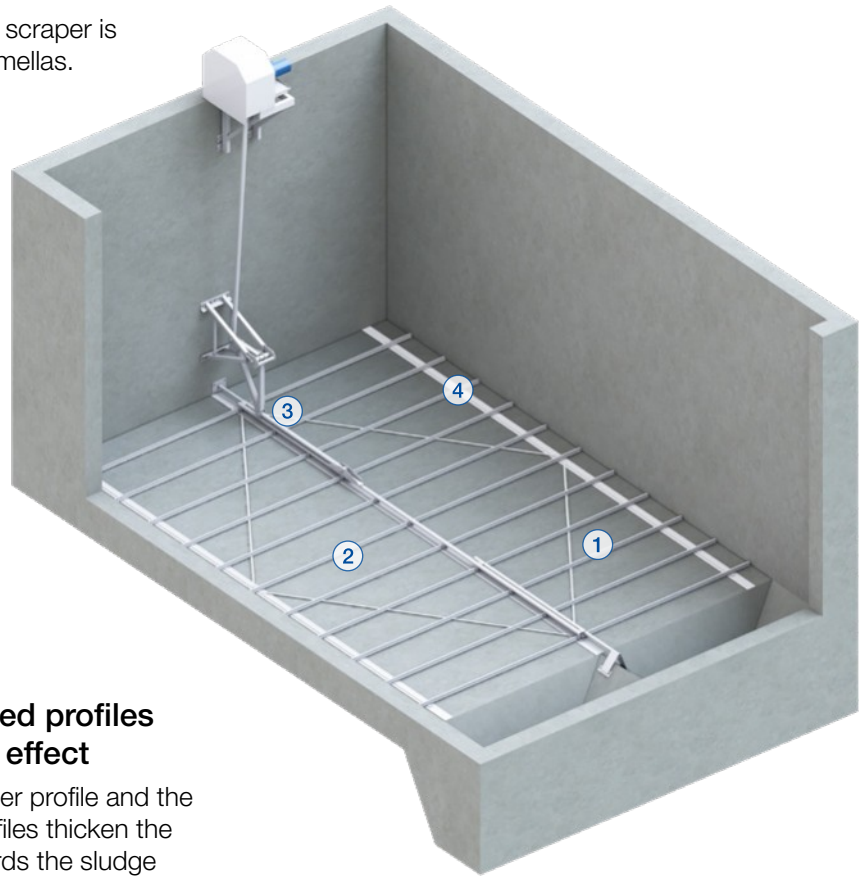

1 Hydrodynamically designed profiles provides sludge thickening effect

- Hydrodynamically shaped scraper profile and the repeated movements of the profiles thicken the sludge as it is transported towards the sludge removal zone
- Continuous sludge removal with each stroke ensures high transportation capacity and keeps a balanced sludge level and avoids undesired sludge build-up

2 Sludge transportation occurs in the very bottom of the sludge layer

- Highly efficient sludge collection without causing any turbulence or disturbance to the sedimentation process or sludge layer
- Lowest part of the sludge layer is continuously removed while the more diluted sludge above is not accompanied, resulting in a dense and highly concentrated sludge product
- The higher solids content reduces the amount transferred to the sludge handling process and provides a dryer sludge which will facilitate dewatering, leading to efficiency improvement and energy savings

3 Increased reliability and low need for maintenance

- The bottom scraper is welded to one complete and robust bottom structure
- Few moving parts and straightforward design that ensures reliable performance and low need for surveillance and maintenance
- All material under water is stainless steel for long life

4 Easy to adapt scraper for use in existing tanks

- Flexible design that facilitates adaption to tanks with pillars or other obstructions inside the tank
- Alternative with fully submerged drive are available
- Multiple units can be installed in wide tanks without the need for further concrete work or support structures

Features and benefits

Circular bridgeless scrapers

1 Unique drive system

- Patented drive design with fixed installation on the tank wall allows for easy electrical access and no need for a concrete structure in the center
- Flexible installation options available - dry installed at the top of the tank or fully submerged drive unit
- The specially designed drive wheel powers provide efficient transmission to the system

2 Drive ring designed to provide long service life

- The drive ring rotates around the tank supported by plastic rollers that distribute the weight evenly and provide low wear and cost-efficient replacement parts
- The lack of bridge structure above water allows low profile cover installation
- Significantly reduced air volume that requires cleaning, compared to a basin cover above a traveling bridge scraper, greatly reduces the air cleaning costs, both for investment and operation

3 Low weight and slick design

- Low energy requirement thanks to efficient drive design and low weight
- Low maintenance needs
- Less raw material and manufacturing lead to a reduced carbon footprint

4 Increased reliability

- All material under water is stainless steel providing a long service life
- No moving parts on top of the tanks results in no operational problems due to snow and ice in cold climates

5 Surface scraper and scum beach

- For applications with floating scum, a surface scraper and scum beach with scum box can be included for collection of surface scum



The Sulzer Flow division keeps your processes flowing. Wherever fluids are treated, pumped, or mixed, we deliver highly innovative and reliable solutions for the most demanding applications.

The Flow division specializes in pumping solutions specifically engineered for the processes of our customers. We provide pumps, agitators, compressors, grinders, screens and filters developed through intensive research and development in fluid dynamics and advanced materials. We are a market leader in pumping solutions for water, oil and gas, power, chemicals and most industrial segments.

E10801 en 9.2024, Copyright © Sulzer Ltd 2024

This brochure is a general presentation. It does not provide any warranty or guarantee of any kind. Please, contact us for a description of the warranties and guarantees offered with our products. Directions for use and safety will be given separately. All information herein is subject to change without notice.

