

SULZER

Nordic Water

PCL series High-rate DAF system

Nordic Water's PCL series DAF removes solids, oils, and FOG using high-rate flotation, crossflow plate packs, and in-tank sludge thickening for high-capacity wastewater applications.

The PCL series high-rate Dissolved Air Flotation (DAF) system from Nordic Water is engineered for maximum performance in high-flow industrial wastewater environments. With a vertical, space-saving design and integrated crossflow plate packs, the PCL series efficiently removes Total Suspended Solids (TSS), Fats, Oils, and Grease (FOG), and other contaminants, delivering drier sludge and clearer effluent with a reduced footprint.



In the PCL series DAF system, clarified effluent is recirculated and saturated with air using an angled air dissolving tube and non-proprietary recycle pump. This creates a whitewater stream filled with microbubbles. When mixed with influent wastewater, the bubbles attach to suspended solids, causing them to rise. A crossflow plate pack improves separation by increasing effective surface area. At the top, floated solids are skimmed off while a dewatering grid thickens sludge, and clarified water exits below.

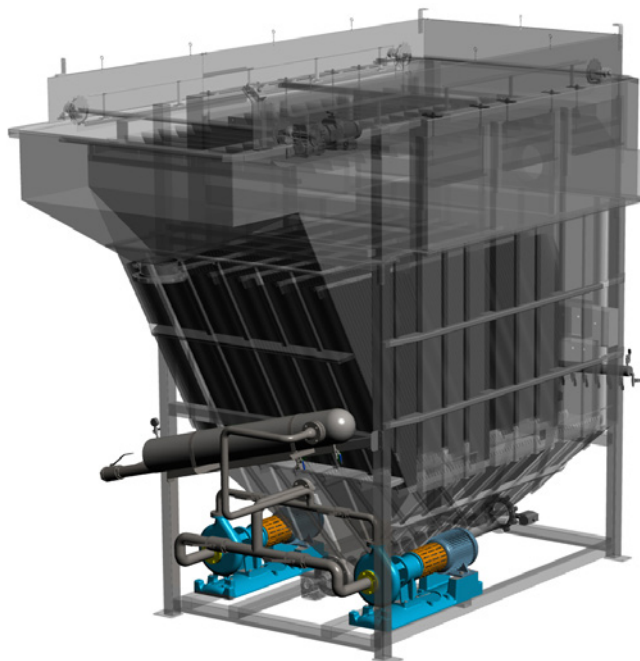

Key features

- Vertical, high-built design for compact installation
- Crossflow plate pack increases separation area and solids capture
- Integrated sludge dewatering grid promotes thicker, drier sludge output
- Angled air dissolving tube for rapid whitewater generation
- Non-proprietary pumps
- Stainless-steel construction resists corrosion in harsh environments
- Fully customizable system configuration including skids, catwalks, and controls

Specifications

- Flow rate: Up to 454.2+ m³/h
- Free separation area: 0.5 - 14.0 m²
- Effective separation area: 3.0 - 288 m²
- Construction: Stainless steel (304, 316, duplex, or custom alloys)

Applications

- Food and beverage processing
- Petrochemical and oil refining
- Pulp and paper industries
- High-load industrial wastewater
- Municipal pretreatment

Why choose the PCL DAF?

The PCL series delivers reliable, high-rate separation with excellent sludge handling and energy efficiency, making it the ideal choice for demanding industrial and municipal wastewater applications.

How can we help you?
Contact us today to find your best solution.

nordicwater.com



E11064 en 4.2026, Copyright © Sulzer Ltd 2026

This brochure is a general product presentation. It does not provide a warranty or guarantee of any kind. Please contact us for a description of the warranties and guarantees offered with our products. Directions for use and safety will be given separately. All information herein is subject to change without notice.